

General tolerances(mm)													
0	>3	>6	>10	>18	>30	>50	>80	>120	>180	>250	>315	>400	0.1/10
~3	~6	~10	~18	~30	~50	~80	~120	~180	~250	~315	~400		
±0.12	±0.18	±0.22	±0.26	±0.31	±0.37	±0.57	±0.80	±0.93	±1.05	±1.15	±1.60	±2.20	±2.50

A

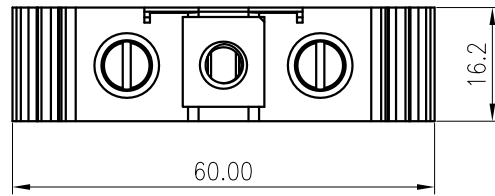

B

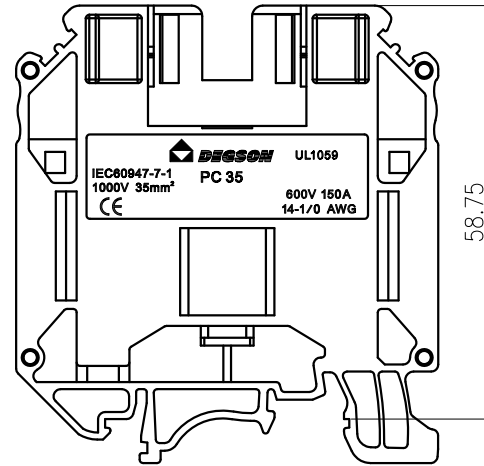
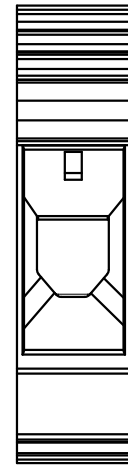
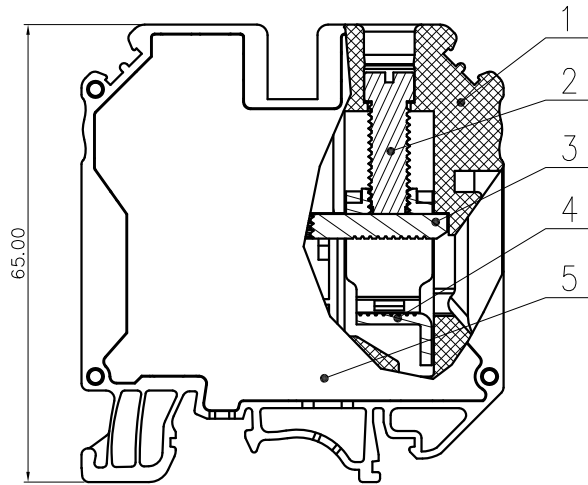

C

UL Standard:	B	C	D
Rated Voltage(V)/Current(A)	600/150	/	/
IEC Standard:			
Overtoltage Category	III/3	/	/
Pollution Degree	III/3	/	/
Rated Voltage(V)/Current(A)	1000/125	/	/
Rate Impulse Voltage(KV)	8.0	/	/
Torque Tightening(N·m/Lb.in)	M6, 2.5/22.15		
Wire Range(rigid and flexible)(mm²/AWG)	1.5~35/14~1/0		
Pitch(mm)/Poles	16.20		
Stripping length(mm)	18-19		
Operating temperature(°C)	-40~+105		
Conform to RoHS	Yes		
Standard color number:	/		
PANTONE / RAL	/		

D

5	Housing2	PA66	UL94V-0
4	Cage	Steel	M6/Zn Plated
3	Current Carrier	Copper	Sn Plated
2	Screw	Steel	M6/Zn Plated
1	Housing1	PA66	UL94V-0
ITEM	NAME OF PART	MATERIAL	NOTES

MATERIAL:	SURFACE:		
MAT NO.:	/		
STATUS:	/		
APPD: Li GL 2020.06.04	NAME: DEGSON ® NINGBO DEGSON ELECTRICAL CO., LTD		
CHKD: Mao J 2020.06.04	PC35-01P-1Y-105A(H)		
DRFT: Feng X 2020.05.30	DRAWING NO.:	PC35-C25	REV T1
⊕	SIZE: A4	SCALE: 1:1	SHEET 1/1

REV	ECN	DESCRIPTION	DRFT	DATE

⊕	SIZE: A4	SCALE: 1:1	SHEET 1/1
---	----------	------------	-----------