

General tolerances(mm)													0.1/10 /2'
0 ~ 3	>3 ~ 6	>6 ~ 10	>10 ~ 18	>18 ~ 30	>30 ~ 50	>50 ~ 80	>80 ~ 120	>120 ~ 180	>180 ~ 250	>250 ~ 315	>315 ~ 400	>400 ~ 500	
±0.12	±0.18	±0.22	±0.26	±0.31	±0.37	±0.57	±0.80	±0.93	±1.05	±1.15	±1.60	±2.20	±2.50

A

A

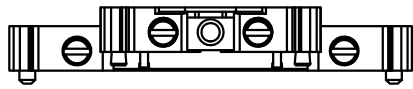

B

B

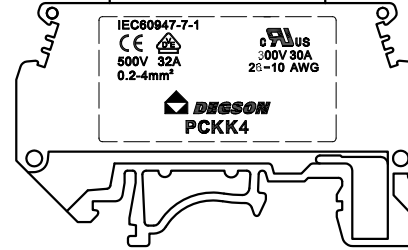
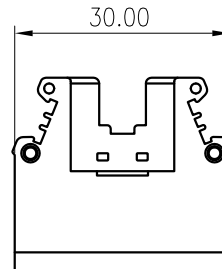
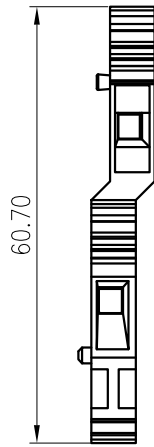
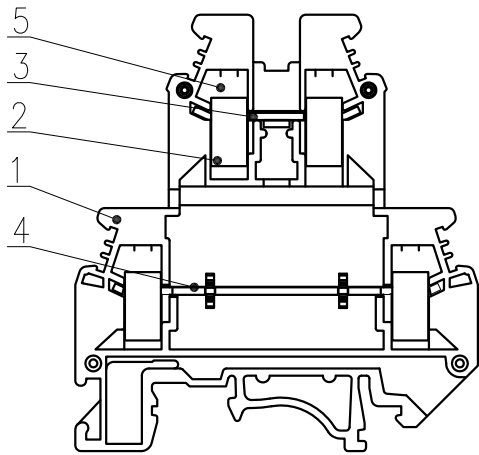

5	Screw	Copper alloy	M3/Ni Plated
4	Short Contact	Copper	Sn Plated
3	Long Contact	Copper	Sn Plated
2	Cage	Copper alloy	M3/Ni Plated
1	Housing	PA66	UL94V-0
ITEM	NAME OF PART	MATERIAL	NOTES

UL Standard: B C D

C

C

D

D

MATERIAL: /	SURFACE: /		
MAT NO.: /	NINGBO DEGSON ELECTRICAL CO., LTD		
STATUS: /			
APPD: LiGL 2020.04.07	NAME: PCKK4		
CHKD: MaoJ 2020.04.07	DRAWING NO.: PCKK4-C01		
DRFT: Wang Y 2020.04.07	REV	TO	
SIZE: A4	TYPE: CUSTOMER DRAWING	SCALE: 1:1	SHEET 1/1

REV	ECN	DESCRIPTION	DRFT	DATE