

General tolerances(mm)												0.1/10 ±Z		
0	>3	>5	>10	>18	>30	>50	>80	>120	>180	>250	>315		>400	>500
±0.12	±0.18	±0.22	±0.26	±0.31	±0.37	±0.57	±0.80	±0.93	±1.05	±1.15	±1.60	±2.20	±2.50	

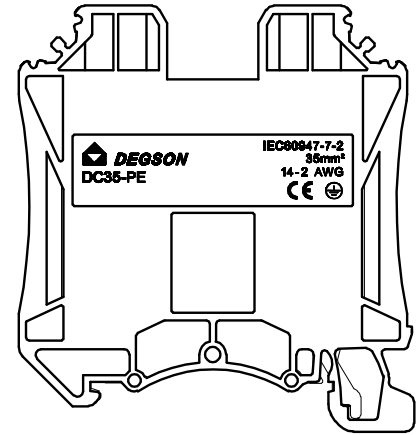
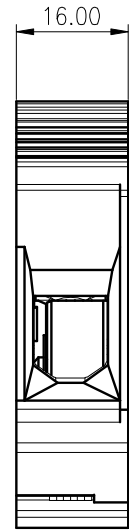
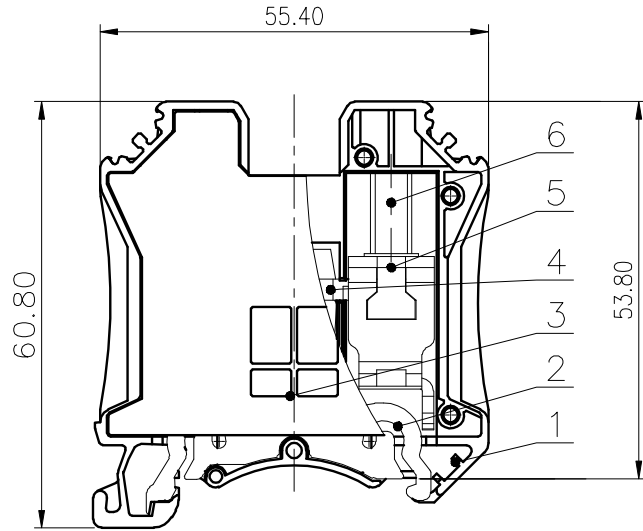
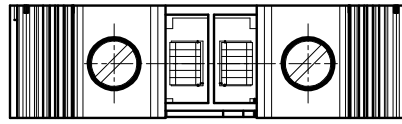

UL Standard:	B	C	D
Rated Voltage(V)/Current(A)	/	/	/
IEC Standard:			
Overvoltage Category	III/3	/	/
Pollution Degree			
Rated Voltage(V)/Current(A)	/	/	/
(KV)/Rate Impulse Voltage(KV)	8.0	/	/
Torque Tightening(N·m/Lb.in)	M6, 3.5/31		
Wire Range(rigid and flexible)(mm²/AWG)	14~2/2.5~35		
Pitch(mm)	16.0		
Stripping length(mm)	14-16		
Operating temperature(°C)	-40~+105		
Conform to RoHS	Yes		
Standard color number:	/		
PANTONE / RAL	/		

6	Screw	Steel	M6\Zn Plated
5	Cage	Steel	Zn Plated
4	Current carrier	Copper	Sn Plated
3	Cover	PA66	UL94V-0
2	Grounding body	Copper alloy	Sn Plated
1	Housing	PA66	UL94V-0

MATERIAL: /	SURFACE: /		
MAT NO.: /	NINGBO DEGSON ELECTRICAL CO., LTD		
STATUS: /			
APPD: Li GL 2020.05.25	NAME: DC35-PE-01P-1C-00A(H)		
CHKD: Mao J 2020.05.25	DRAWING NO.: DC35-PE-C01		
DRFT:Wang LX 2020.05.25	REV		TO-2

ITEM	NAME OF PART	MATERIAL	NOTES	REV	ECN	DESCRIPTION	DRFT	DATE	SIZE: A4	TYPE: CUSTOMER DRAWING	SCALE: 1:1	SHEET	1/1
------	--------------	----------	-------	-----	-----	-------------	------	------	----------	------------------------	------------	-------	-----