

General tolerances(mm)													0.1/10 ±2'
0	>3	>6	>10	>18	>30	>50	>80	>120	>180	>250	>315	>400	
~3	~6	~10	~18	~30	~50	~80	~120	~180	~250	~315	~400	~500	>500
±0.12	±0.18	±0.22	±0.26	±0.31	±0.37	±0.57	±0.80	±0.93	±1.05	±1.15	±1.60	±2.20	±2.50

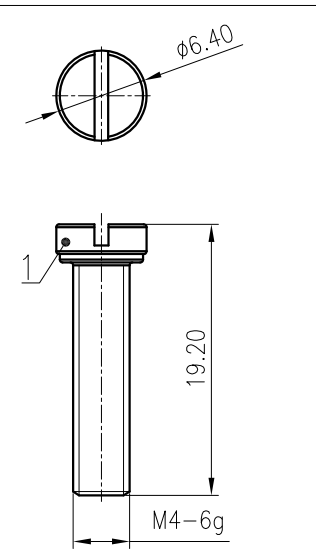
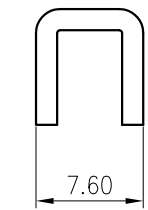
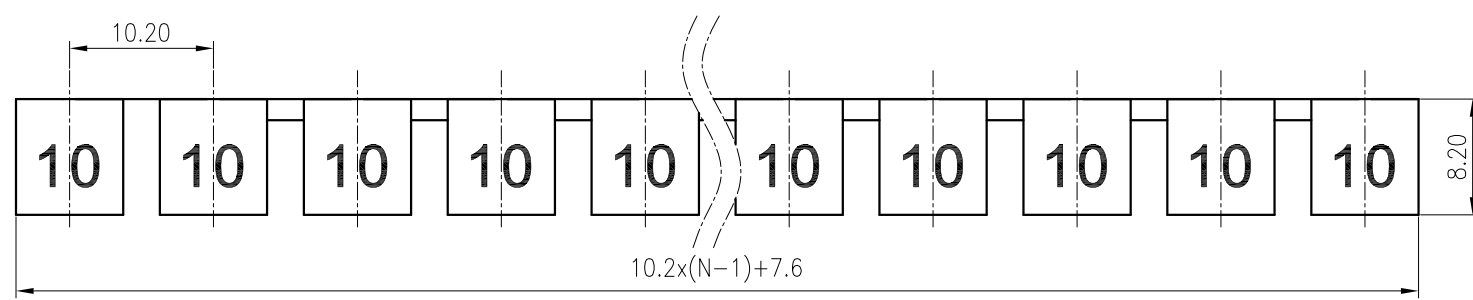
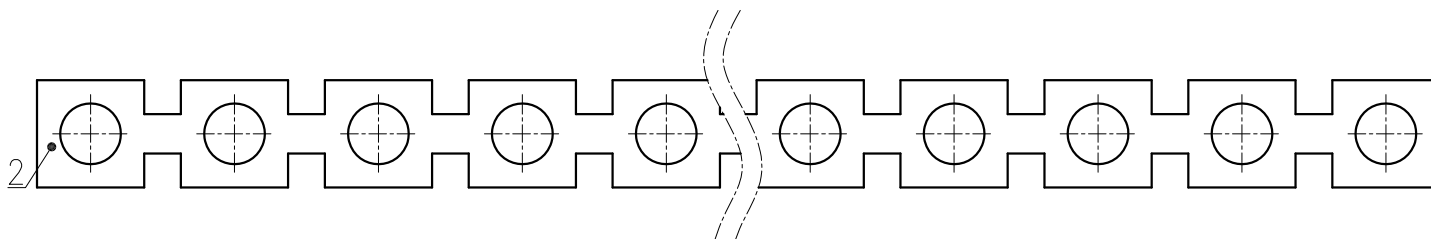

ITEM	PART NAME	MATERIAL	NOTES
2	Current carrier	Copper	Sn Plated
1	Screws	Copper alloy	Ni Plated
Torque Tightening(N·m/Lb.in)		M4,1.2/10.53	
Pitch(mm)/Poles		10.2/N=02P~10P	
Operating temperature(°C)		-40~+105	
Current carrier and Screws should be packed individually,which must be put in the same box			
Conform to RoHS		Yes	

MATERIAL:	/	SURFACE:	/
MAT NO.:	/	NINGBO DEGSON ELECTRICAL CO., LTD	
STATUS:	/		
APPD:	Li GL 2020.06.04	NAME: FBI10-10	
CHKD:	Mao J 2020.06.04	DRAWING NO.: FBIXX-10-C01	
DRFT:	Chen K 2020.06.04	REV	T2
SIZE: A4	mm (inch)	TYPE: CUSTOMER DRAWING	SCALE: 2:1
		SHEET	1/1

REV	ECN	DESCRIPTION	DRFT	DATE