

General tolerances(mm)											0.1/10 ±2'		
0	>3	>6	>10	>18	>30	>50	>80	>120	>180	>250		>315	>400
±0.12	±0.18	±0.22	±0.26	±0.31	±0.37	±0.57	±0.80	±0.93	±1.05	±1.15	±1.60	±2.20	±2.50

A

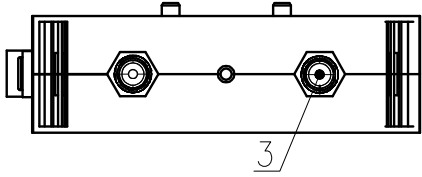

B

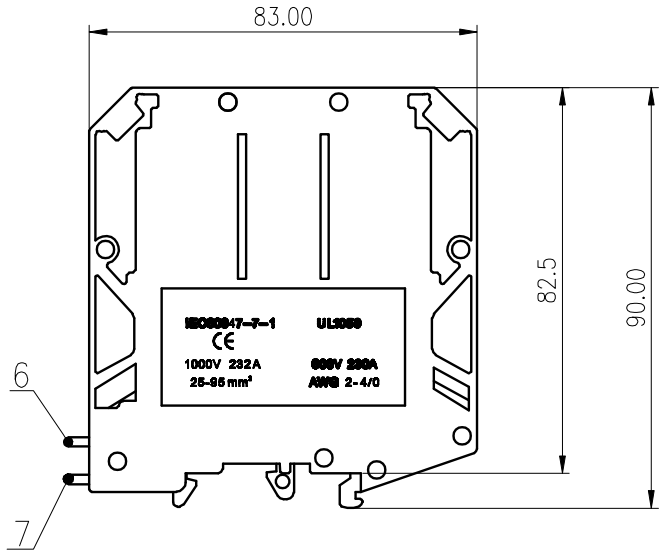

C

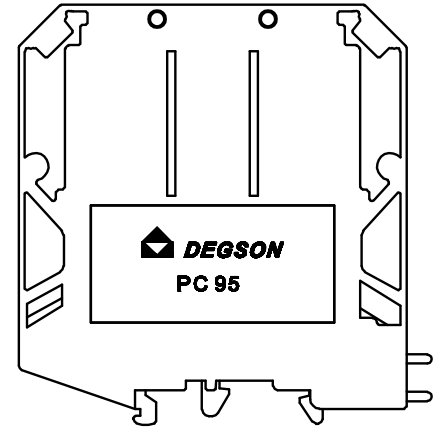
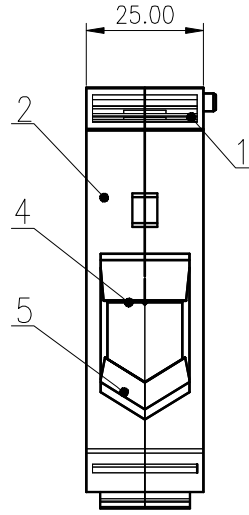
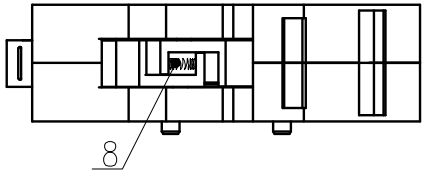

UL Standard:	B	C	D
Rated Voltage(V)/Current(A)	600/230	/	/
IEC Standard:			
Overvoltage Category	III/3	/	/
Pollution Degree			
Rated Voltage(V)/Current(A)	1000/232	/	/
(KV)/Rate Impulse Voltage(KV)	8	/	/
Torque Tightening(N·m/Lb.in)	M8, 20/177		
Wire Range(rigid and flexible)(mm²/AWG)	25~95/2~4/0		
Pitch(mm)	25.0		
Stripping length(mm)	33~35		
Operating temperature(°C)	-40~+105		
Conform to RoHS	Yes		

8	Spring	Spring Steel	Ni plated
7	Sliding part 2	PA66	UL94V-0
6	Sliding part 1	PA66	UL94V-0
5	Groupware		
4	Current Carrier	Copper	Sn plated
3	Screw	Steel	Zn plated
2	Housing2	PA66	UL94V-0
1	Housing1	PA66	UL94V-0
ITEM	NAME OF PART	MATERIAL	NOTES

MATERIAL: /	SURFACE: /		
MAT NO.: /	NINGBO DEGSON ELECTRICAL CO., LTD		
STATUS: /			
APPD: Li GL 2020.05.30	NAME: PC95-01P-1Y-00A(H)		
CHKD: Mao J 2020.05.30	DRAWING NO.: PC95-C02		
DRFT:ZhengQG 2020.05.16	TYPE: CUSTOMER DRAWING		REV T2
⊕	SIZE: A4	SCALE: 1:1.5	SHEET 1/1